

## UGS NX Mach Series Machining solutions

Improving productivity in NC programming and machining, die and mold manufacturing

### fact sheet

UGS PLM software

[www.siemens.com/ugs](http://www.siemens.com/ugs)

#### ► Summary

UGS NX™ software, the digital product development system from UGS PLM Software, offers several prepackaged Mach Series solutions for NC machining. Available in a range of capability levels, these solutions accelerate programming and improve productivity for a variety of typical manufacturing challenges, from basic machining to complex, multiple-axis and multi-function machining, as well as mold and die manufacturing. The packages include complete capabilities for geometry import, CAD modeling and drafting, full associativity to part designs, NC tool path creation, verification and postprocessing, along with productivity tools that streamline the overall machining process.

#### Benefits

Improves manufacturing productivity  
Maximizes value of the latest machine tool technology  
Improves NC program quality  
Eliminates requirements for separate systems

#### Features

Integrated design-through-manufacturing (CAD/CAM) solutions with data management  
Packages tailored for specific machining requirements  
Comprehensive NC programming – tool path creation, verification, simulation, postprocessing, and productivity aids  
Design-to-manufacturing associativity  
Proven, in-depth capability

The NX® Mach Series Machining solutions include:

- *NX Mach 1 – 2½-Axis Machining* software, which provides the basic milling and turning capabilities needed in the machinery industry, or for other 2-axis applications such as finishing castings.
- *NX Mach 2 – 3-Axis Machining* software, which provides a full complement of 3-axis milling and drilling capabilities well-suited for the most demanding mold and die machining.
- *NX Mach 2 – Mill-Turn Machining*, which provides all the components needed to effectively program multi-function equipment such as mill-turn combination machines.
- *NX Mach 3 – Advanced Machining*, which is configured to program 5-axis machine tools, including multi-function 5-axis mill-turn machines.
- *NX Mach 4 – Advanced Mold Manufacturing*, which provides advanced mold design and manufacturing functionality, step-by-step guidance and full associativity to part designs.
- *NX Mach 4 – Advanced Die Manufacturing*, which provides a comprehensive solution for quality die design and manufacturing, with full associativity to part designs throughout the development process.

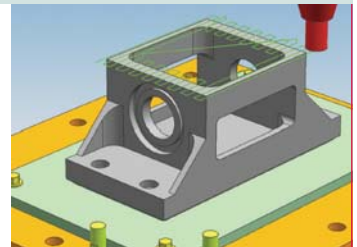

*NX Mach 1 – 2½-Axis Machining is well suited for the machinery industry.*

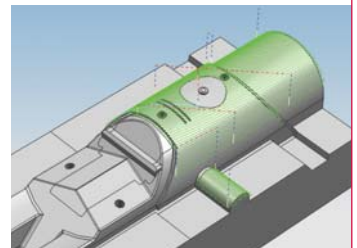

*NX Mach 2 – 3-Axis Machining is configured especially for tooling manufacturers.*

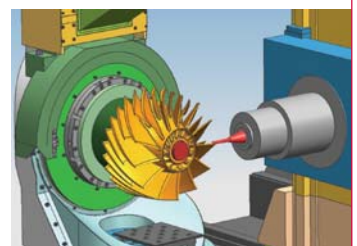

*NX Mach 3 – Advanced Machining has the capability to take on any machining task within NX.*

**UGS NX 4 Mach Series**

<i>Product content overview</i>	<i>NX Mach 1 2-1/2 Axis Machining</i>	<i>NX Mach 2 3-Axis Machining</i>	<i>NX Mach 2 Mill-Turn Machining</i>	<i>NX Mach 3 Advanced Machining</i>	<i>NX Mach 4 Advanced Mold Manufacturing</i>	<i>NX Mach 4 Advanced Die Manufacturing</i>
<i>Product number</i>	<i>NX11420</i>	<i>NX12420</i>	<i>NX12430</i>	<i>NX13420</i>	<i>NX14400</i>	<i>NX14410</i>
Data translation	•	•	•	•	•	•
General NC programming tools	•	•	•	•	•	•
Machining wizard builder	•	•	•	•	•	•
Feature-based hole making/machining	•	•	•	•	•	•
Fixed-axis milling						
Planar milling	•	•	•	•	•	•
Core and cavity milling	•	•	•	•	•	•
Fixed-axis surface milling		•		•	•	•
Facet machining		•		•	•	•
Flow cut milling		•		•	•	•
NURBS path generator		•		•	•	•
Turning	•		•	•	•	•
Wire EDM		•		•	•	•
Five-axis machining						
Variable-axis milling and profiling				•	•	•
Sequential milling				•	•	•
Multi-function machine synchronization			•	•	•	•
Machining simulation			•	•	•	•
Postprocessing	•	•	•	•	•	•
Shop documentation	•	•	•	•	•	•
Engineering process management/CAM data management	•	•	•	•	•	•
CAD tools	•	•	•	•	•	•
Advanced design tools		•		•	•	•
Mold design					•	
Progressive die design						•
Electrode design					•	•

### UGS NX Mach Series Machining solutions capabilities

NX Mach Series Machining solutions provide all the tools you need to create, refine and optimize NC tool paths as well as state-of-the-art solutions for progressive die and mold design. From geometry import through simulation and postprocessing, these solutions deliver comprehensive NC programming plus mold and die design capabilities in a fully integrated system.

#### Data translation

All of the NX Mach Series Machining solutions include data exchange tools for importing CAD part geometry from a broad range of sources. NX machining works directly with NX geometric models, and is associatively interoperable with models created with NX I-deas® software or UGS Solid Edge™ software. Since NX is built with UGS PLM Software's Parasolid® software modeling kernel, the *de facto* industry standard, it also easily reads Parasolid data from many CAD systems. NX also translates data from several standard exchange and neutral formats, including IGES, STEP 203 and 214, DXF and DWG.

Programmers using any of the NX Mach Series Machining solutions can also select parts from NX assembly models for machining.

#### NC tool path creation and programming

##### General NC programming tools

All NX Mach Series Machining solutions include tools for creating and editing NC programs. The base capability enables programmers to edit cutter location source files, to reorder tool paths within the cutter location files and to program point-to-point, drive curve machining and drilling. In addition, programmers can graphically display NX tool paths and upon selection of a graphical element, can edit the graphical component or its corresponding textual representation (GOTO statements).

In addition, the NX machining solutions can readily interface with resource libraries of cutters, feeds and speeds and machine tool information. The interface enables programmers to search, review and retrieve resource information through NX query dialogs.

##### Machining wizard builder

All of the NX Mach Series Machining solutions include a machining wizard builder. This capability enables companies to capture standard machining procedures and company best practices in step-by-step wizards that help automate NC programming. The custom wizards can be re-used throughout the company to assist less experienced programmers and to promote standardization of NC machining practices.

##### Feature-based machining

The NX Mach Series Machining solutions automate NC programming with feature-based machining, which can reduce programming time and effort by 90 percent. Feature-based machining automatically recognizes machining features in the part model and sorts them by feature type. NX CAM then selects machining methods appropriate to each feature type, applying templates, rules and machining parameters automatically. Automated tool path creation then creates the tool paths, selects tools and optimizes the paths for tool type and tool path length. Output includes the final NX program and associated shop documentation.

##### Fixed-axis milling

*Planar milling* – All NX Mach Series Machining solutions support planar milling operations including multiple-pass profiling and follow pocketing, and include three linear motion area clearance routines. The software automatically creates tool paths for pre-drilling holes and machining around multiple islands.

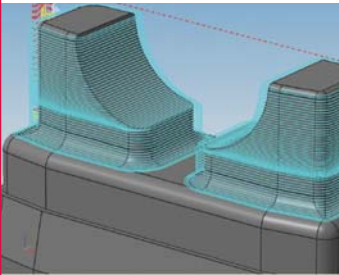

*Core and cavity milling* – All NX Mach Series Machining solutions create tool paths for fixed-axis core and cavity milling. The tool paths remove volumes of material in planar layers that are perpendicular to the fixed tool axis. This type of machining operation is most commonly used to rough out material from cores and cavities in preparation for finishing. Multiple cutter trajectory options are available, as well as control for high speed machining. Initial stock material and in-process material can be used to define machining regions, thereby avoiding unnecessary cutter moves.

*Fixed-axis surface milling* – enables 3-axis machining of surfaces and solids. NX includes a broad selection of drive methods including boundary, radial cut, spiral cut and user-defined. Boundary drive methods offer cut patterns that include concentric and radial patterns. The software features controls for upward and downward cutting and helical engages, and geometry creation to identify uncut or cleanup areas.

*Facet machining* – creates tool paths for machining faceted models such as STL (rapid prototyping format) or Parasolid faceted bodies. This capability can be used in reverse engineering from scanned models.

*Flow cut milling* – generates fixed contour tool paths along concave corners and valleys formed by part surfaces. NX automatically determines the direction and order of the flow cuts using rules based on machining best practices. The resulting tool path is optimized to maintain tool contact with the part and minimize non-cutting moves. Manual assembly is available for the cases where human intervention can improve the results.

*NURBS path generation* – provides a machine control dialog with an option for output of non-uniform rational B-spline (NURBS) tool path, the application code for the generation of the tool path and the necessary enhancements to postprocess the new format. The format is supported by machine controllers that have NURBS interpolation option.

### Five-axis machining

*Sequential milling* – NX includes tool path creation for machining a series of edge-to-edge surfaces (sheets or faces) in succession. This sequential milling capability is used to finish surfaces once the area has been roughed out with planar or cavity milling. The software creates tool paths that carefully follow surface contours using three-, four- or five-axis tool movements while exercising a high degree of control over each tool move.

*Variable-axis milling and profiling* – NX supports both fixed and multi-axis milling functions on any NX part surfaces.

Programmers can specify full 3- to 5-axis contouring motion, tool orientation and quality of surface finish. Tool paths may be controlled by surface parameters, by projecting tool paths onto the surface and by arbitrary curves or points.

NX creates tool paths for profile contour milling operations that semi-finish and finish walls. The software defines the tool axis so that the cutter removes material with its side only. For example, upon selection of a cavity floor, the software will create tool paths for all the walls surrounding the floor in that region. If multiple floors are selected in a single operation, then all the surrounding walls will be machined.

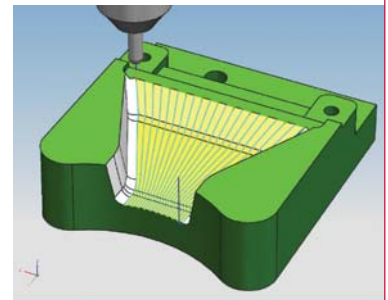

### Multi-function machine synchronization

Harness the power of multi-function machine tools with a graphical means of displaying an unlimited number of channels, with scrolling code in a choice of formats, time displays and functions to add wait and sync codes. The Synchronization Manager is directly linked to the internal postprocessor and runs from posted output for the greatest accuracy.

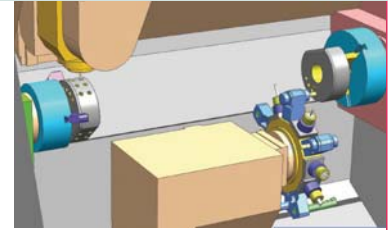

### Turning

NX Mach 1 through Mach 3 packages include a comprehensive solution that is easy enough to use on simple programs and capable enough to tackle your toughest geometry in multi-spindle, multi-turret applications.

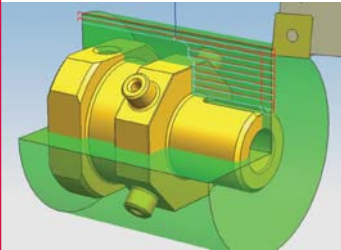

### Wire EDM

NX Mach 2 through Mach 3 Machining solutions create tool paths for wire electrical discharge machining of parts in 2- through 4-axis mode. The software works with parts defined in wireframe or solid geometry. It supports a range of wire EDM operations including multi-pass profiling, wire reversing and area removal.

NX automates tool path creation for machining holes, pockets and faces with feature-based machining. This advanced capability automatically recognizes features in NX design models, including user-defined features and geometry items with machining feature attributes. The software applies templates with pre-defined processes for each feature type and rules for adjusting the process for specific geometry and material conditions. According to the rules, multiple operations are provided for machining the features, including tool selection and parameter settings. An optimization procedure consolidates tool selections and optimizes tool motions across the feature sets.

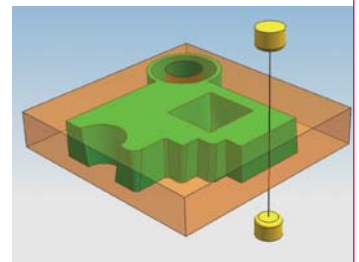

### Machining simulation and tool path verification

*Toolpath verification* – All NX Mach Series Machining solutions provide visualization capabilities that display, animate and verify NX tool paths for milling and turning. The visualization enables shaded display and storage of the in-process workpiece and standard display of the tool path and holder with gouge detection. The software animates the material removal process and provides analysis tools for remaining material and undercutting.

*Machining simulation* – Avoid tying up a machine in unproductive prove-outs with the integrated machine tool simulation capability in the NX Mach 2, Mach 3 and Mach 4 Machining packages. Users will be able to detect collisions using a set of pre-defined generic machine tools. In addition, a machine tool builder enables companies to create and simulate customized machine tool/controller combinations. The software simulates tool paths and machine tool G and M code programs. Custom machines can be stored and retrieved in optional UGS library tools. Plus, special tools are provided to build complete kinematic machine tool models.

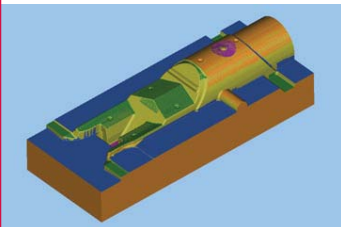

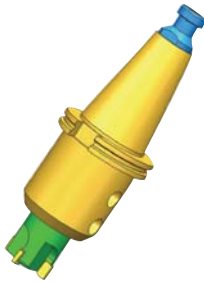

### Postprocessing

*Post builder* – All NX Mach Series Machining solutions include an interactive postprocessor generator that creates NC postprocessing programs used to produce machine-specific output from NX tool paths. Standard milling, drilling and turning machines are supported. The postprocessor development tools include Windows-like structures with drag-and-drop options for defining the postprocessor parameters. In addition, the output can be manually modified by users with programming experience to extend the postprocessing features. Postprocessors can be executed to convert NX tool paths to machine-ready programs.

An *advanced kinematics* library is included in all the NX Mach Series Machining solutions. The advanced kinematics are required for postprocessing advanced machine tools with non-orthogonal heads.

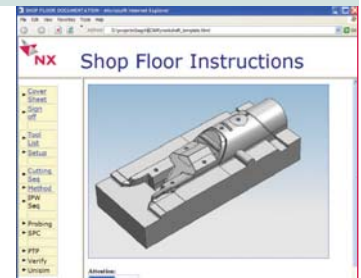

### Design and drafting

All of the NX Mach Series Machining packages include powerful design tools for a complete CAD/CAM solution. The geometry creation and editing capabilities include solid modeling and feature-based, parametric design, assembly modeling, basic freeform surface modeling for complex shapes and sheet metal component design. Full production drafting is also provided for creating and maintaining engineering drawings.

The CAD tools in NX Mach Series Machining solutions are complemented by many design productivity aids. Stress and vibration wizards help non-experts simulate performance of parts or manufacturing components. User-defined features assist in creating and re-using common design features. Rapid prototyping output automatically prepares component data for stereolithography and other rapid prototyping machines. The ability to run custom programs helps automate best practices and repetitive tasks. A web publishing utility streamlines creation of design and manufacturing information for the Internet or company intranets. Design reviews can be conducted more quickly with XpresReview tools that automatically package information for e-mail distribution.

### Advanced design tools

NX Mach 2 3-Axis Machining, Mach 3 Advanced Machining and Mach 4 Advanced Mold and Advanced Die Manufacturing deliver additional design tools for more complex CAD/CAM challenges. These include full 3D annotation for adding product and manufacturing information (PMI) to 3D models, with complete geometric dimensioning and tolerancing; advanced freeform surface modeling; flexible printed circuit board design; automated checking tools that continuously validate designs for adherence to company and engineering standards; and visualization tools for dynamic and photorealistic rendering.

### Mold design tools

NX Mach 4 Advanced Mold Manufacturing includes high-performance design tools for injection mold making:

*Mold design* – NX mold design combines industry knowledge and best practices with process automation in a state-of-the-art solution that streamlines the entire mold development process. From part design to tool layout, tool design and tool validation, NX mold design excels at even the most challenging mold designs, providing advanced functionality, step-by-step guidance and associativity with part designs to ensure quality molds and quick response to design changes.

The software provides a wealth of industry best practices and process solutions for:

- Part and assembly design
- Manufacturability assessment
- Core and cavity design
- Electrode design
- Mold design and assembly
- Mold tool validation
- Design change management
- Collaboration

#### Progressive Die Design

NX Mach 4 Advanced Die Manufacturing includes high-performance tools for progressive die design.

NX Progressive Die Design streamlines the die development process, from design through to tool validation. NX Progressive Die Design is a comprehensive solution for quality die design, supporting associativity with the part design at every stage of die development and including a variety of functions specific to progressive dies, including:

- Sheet metal parts and blank design
- Strip design and simulation
- Die base, insert and assembly design
- Electrode design
- Tool validation
- Design change management

#### Shop documentation

All NX Mach Series Machining solutions include tools for creating NC program documentation for use on the shop floor. The output can be configured to produce ASCII files, HTML (viewable from a web browser) and other formats.

#### Engineering process management and CAM data management

*Engineering process management* – Engineering process management, powered by UGS Teamcenter™ technology, is a foundation product data management system integrated with all NX solutions. It provides a variety of capabilities for vaulting, sharing and securing product data across distributed organizations that can be deployed to meet the challenges of today and scaled to meet those of tomorrow. Engineering process management organizes and protects all part data (including models, drawings, images, technical documents and manufacturing related information), as well as NC programming resource data and program files. With comprehensive search tools, engineering process management saves time locating product and manufacturing data and helps coordinate the work of all team members.

#### ► Contact

UGS PLM Software

Americas 800 498 5351

Europe +44 (0) 1276 702000

Asia-Pacific 852 2230 3333

[www.siemens.com/ugs](http://www.siemens.com/ugs)



**St.Hua Pte Ltd**

**St.Hua Private School**

CAD/CAM/CAE Engineering Solutions & Training Provider

Address: BLK 131 Jurong East St 13, #04-241 Singapore 600131

Tel: (65) 6561 3877

Fax: (65) 6561 9679

Email: [info@sthua.com](mailto:info@sthua.com)

Website: <http://www.sthua.com>

**SIEMENS**